

REVISIONS					
REV	DESCRIPTION	BY	DATE	CHKD	APPD
A					

Screw is 2-28 x0.375 T-7

Any screw other than the one under the warranty tamper label may be removed and replaced without voiding the warranty for the purpose of mounting the signature pad to an external plate or surface.

The replacement screws must be of the same thread type and diameter and not extend into the pad more than 0.46 as measured from the bottom surface.

Damage caused by screws that are too long or by screws that do not secure the case together will not be covered under warranty.

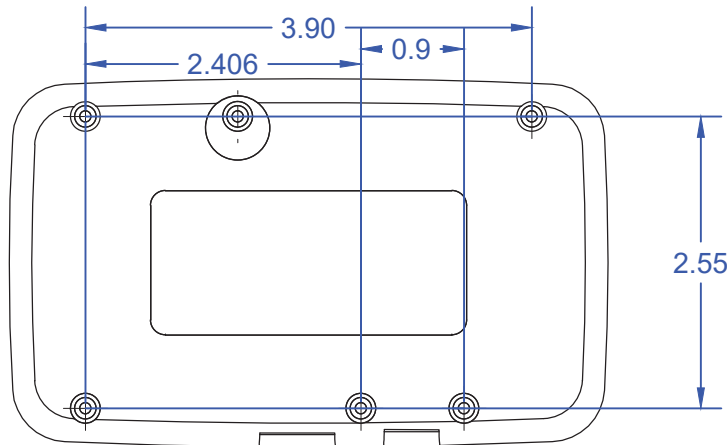

QTY.	U.M.	DESCRIPTION	PART NUMBER	ITEM
PARTS LIST				
<small>THIS DRAWING IS THE PROPERTY OF SCRIPTEL CORPORATION. ANY PATENTS OBTAINED COVERING DESIGN OR CONSTRUCTION SHOWN HEREON BELONG WHOLLY TO SCRIPTEL CORPORATION. THIS DRAWING IS TRANSMITTED AS A CONFIDENTIAL DISCLOSURE AND IS RETURNABLE UPON REQUEST. IT MAY NOT BE COPIED OR ITS CONTENTS REVEALED TO OUTSIDE PARTIES WITHOUT THE WRITTEN PERMISSION OF SCRIPTEL CORPORATION.</small>		<small>UNLESS OTHERWISE SPECIFIED DIMENSIONS ARE IN INCHES. TOLERANCES ARE:</small> FRACTIONS DECIMALS ANGLES \pm .XX \pm .010 \pm 1/2" <small>XXX \pm .005</small>	SCRIPTEL CORPORATION <small>COLUMBUS, OHIO</small> Screw Hole Pattern for ST1550	
PROJECT No:		DRAWN PP 9/27/19	SIZE B	REV.
DO NOT SCALE DRAWING		CHECKED	DWG. NO.	
APPROVALS		APPROVED	SCALE 1X	SHEET 1 OF 1
DATE			© 2019 SCRIPTEL CORP.	