

REVISIONS					
REV	DESCRIPTION	BY	DATE	CHK'D	APP'D
A					

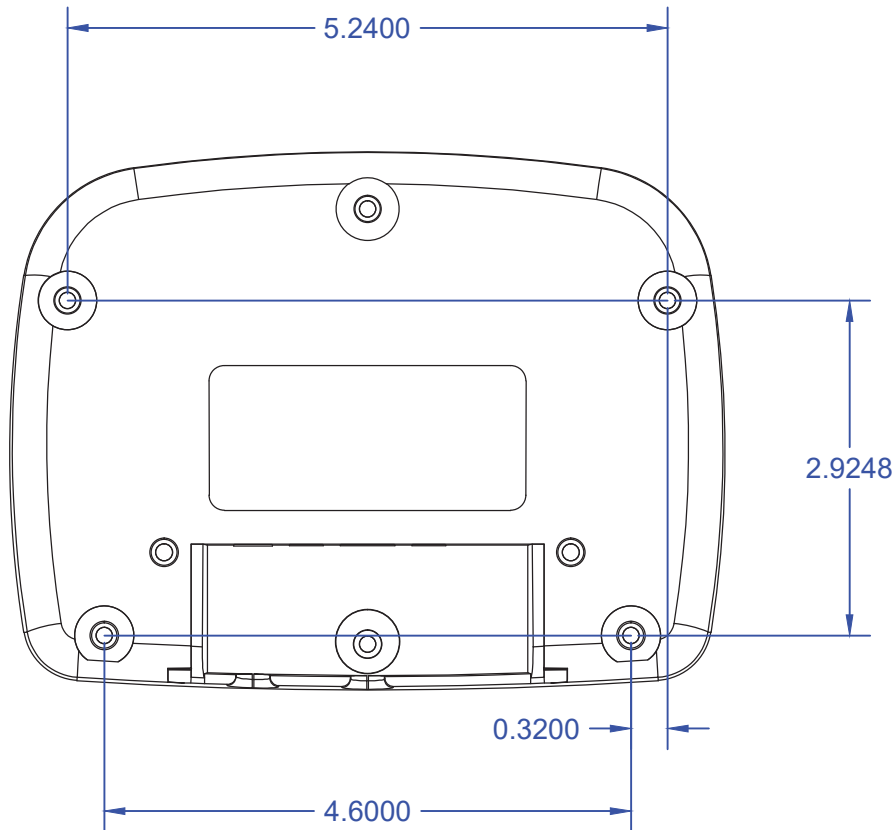

Screw is 4-20 x 0.375 T10

Any screw other than the one under the warranty tamper label may be removed and replaced without voiding the warranty for the purpose of mounting the signature pad to an external plate or surface.

The replacement screws must be of the same thread type and diameter and not extend into the pad more than 1.119 as measured from the bottom surface.

Damage caused by screws that are too long or by screws that do not secure the case together will not be covered under warranty.

QTY.	U.M.	DESCRIPTION	PART NUMBER	ITEM
PARTS LIST				
<small>THIS DRAWING IS THE PROPERTY OF SCRIPTEL CORPORATION. ANY PATENTS OBTAINED COVERING DESIGN OR CONSTRUCTION SHOWN HEREON BELONG WHOLLY TO SCRIPTEL CORPORATION. THIS DRAWING IS TRANSMITTED AS A CONFIDENTIAL DISCLOSURE AND IS RETURNABLE UPON REQUEST. IT MAY NOT BE COPIED OR ITS CONTENTS REVEALED TO OUTSIDE PARTIES WITHOUT THE WRITTEN PERMISSION OF SCRIPTEL CORPORATION.</small>		<small>UNLESS OTHERWISE SPECIFIED DIMENSIONS ARE IN INCHES. TOLERANCES ARE: FRACTIONS DECIMALS ANGLES ± .XX ± .010 ± 1/2" .XXX ± .005</small>	SCRIPTEL CORPORATION <small>COLUMBUS, OHIO</small>	
<small>PROJECT No:</small>		<small>DRAWN</small> PP 10/4 /19 <small>CHECKED</small> <small>APPROVED</small>	Screw Hole Pattern 1525	
<small>DO NOT SCALE DRAWING</small>		<small>APPROVALS</small>	<small>DATE</small>	<small>SCALE</small> 1X <small>SIZE</small> B <small>DWG. NO.</small> <small>REV.</small>
<small>© 2019 SCRIPTEL CORP.</small>			<small>SHEET 1 OF 1</small>	